

COMMERCIAL PIGGYBACK PUMP
We Can Make Any Commercial Piggyback Pump

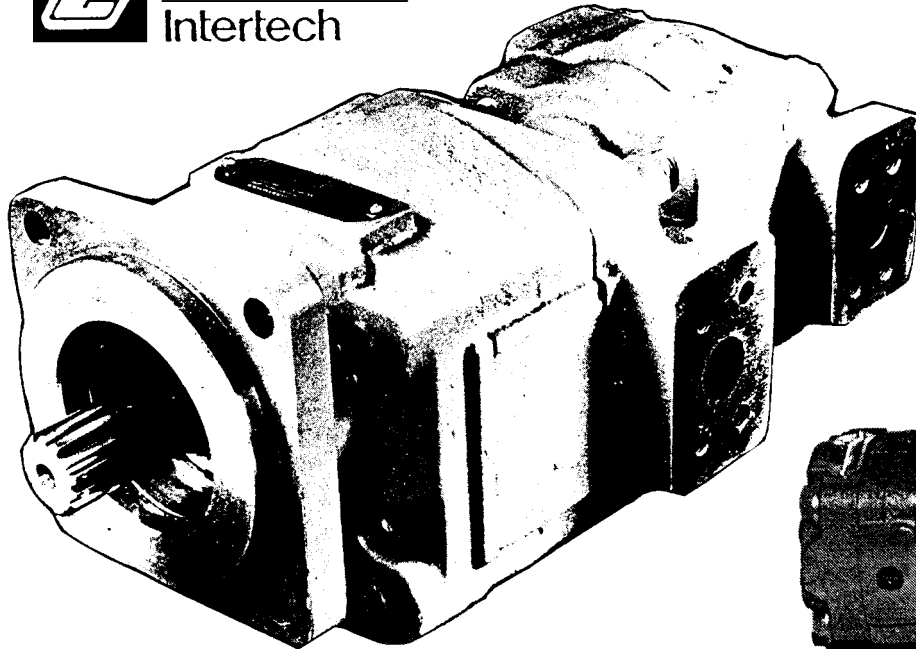

PIGGYBACK PUMP WITH
ONE COMMON INLET
BUSHING STYLE PUMP
P365/P330



PIGGYBACK PUMP
WITH TWO INLETS
P75/P30

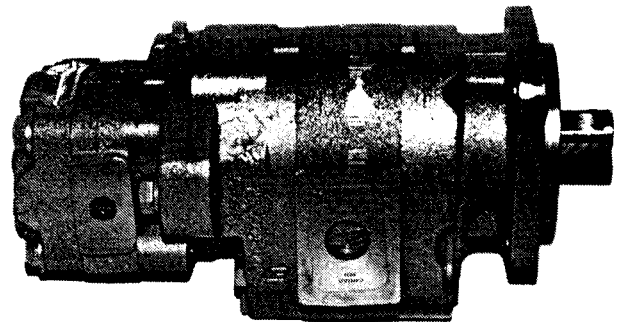

FOR ALL UNITS

To determine direction of shaft rotation, view the unit with the shaft pointing toward you, and the idler (driven) gear beneath the shaft. With clockwise rotation, flow will be left to right. The inlet port will be on the left, outlet on the right. The flow is in the opposite direction with counter-clockwise rotation. Inverting the pump will reverse the inlet and outlet ports but not the direction of rotation.

PIGGYBACK UNITS

Piggyback, multiple pumping assemblies combine separate hydraulic pumps on one common drive shaft. These units are assembled with standard P30, P31, P50, P51, P75, or P76 pumps as the front section, and the same or smaller series pumps as the second, or even third, sections. Fluid from separate reservoirs, as well as different types of hydraulic fluids, can be pumped with piggyback units without intermixing. This allows the designer more freedom with reservoir capacities and oil specification.

The piggyback configuration also provides a much greater range of pump outputs than is available from standard multiple units by allowing the pump sections to be sized for optimum efficiency. For example, a main system might require 100 GPM as a primary supply and 15 GPM as a secondary supply. The ideal assembly would be a P75 with a 3" gear producing 100 GPM at 2000 RPM and a P30 with a 1" gear supplying 15 GPM at the same speed.

Applications for piggyback pumps are usually found where the range of pump outputs is not within conventional multiple pump capabilities. Examples are main and steering systems, main system and torque converter supercharging, steering system and torque converter supplies. Other applications include those using two reservoirs or a reservoir and a sump which require the separation of pumped fluids.

Some of the best uses for piggyback pumps are on utility vehicles, articulated front-end loaders and shovel loaders.

MULTIPLE UNITS

Each section of a multiple pump should be regarded as a single pumping unit with corresponding delivery and power input requirements. Since the entire input is fed through the drive shaft, the power delivered to or from the pump is limited by the physical strength of the shaft.

CODING PIGGYBACK ASSEMBLIES

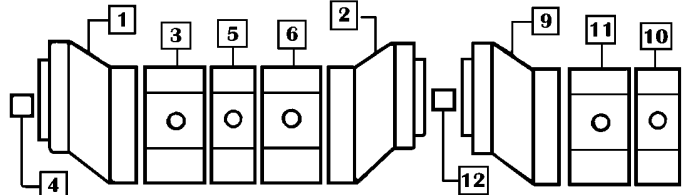

Piggyback assemblies are coded starting from the shaft end cover the same as Commercial's multiple pumps. Codes shown on this catalog page pertain to the special piggyback components.

CODE EXPLANATION

P50B 142 KO OV22-7 COJ12-1/P30A 191 BE OJ15-22

Underlined codes are special piggyback components.

Pump Series Model	P 50 B	1. Gear Housing	2. Port End Cover	3. Gear Housing	4. Drive Shaft	5. Bearing Carrier	6. Gear Housing	7. Connecting Shaft (Not Shown)	9. Shaft End Cover	10. Port End Cover	11. Gear Housing	12. Piggyback Shaft	142 KO OV22 7 C OJ12 1 191 BE OJ15 22
-------------------	--------	-----------------	-------------------	-----------------	----------------	--------------------	-----------------	---------------------------------	--------------------	--------------------	------------------	---------------------	---------------------------------------

Piggyback Component	ASSEMBLY MODEL				
	30/30 31/31	50/30 51/31	75/30 76/31	50/50 51/51	75/50 76/51
Port End Cover					
CW	KO	KO	KO	KO	KO
CCW	LO	LO	LO	LO	LO
BOTH	MO	MO	MO	MO	MO
Shaft End Cover					
Second Unit					
CW	191	191	192	191	192
CCW	291	291	292	291	292
BOTH	391	391	392	391	392
Piggyback Shaft	14	22	23	22	23

COMMERCIAL PUMPS CARRIED IN STOCK



Side-PEC means
Side Ports in
Port End Cover
as shown in photo

Side means
Side Ports in
Gear Housing



TO CHANGE ROTATION on pumps with ports in housing, rotate housing 180° & rotate both wear plates 180° taking care not to lose the very small pocket seals in the wear plates. If pump does not have 2 check valves, move plug from one side to the other in the shaft end cover.

On all pumps direct drive is best. When using direct drive an outboard bearing is not necessary. If there is any side load on the pump due to a driveline or belt pulley or chain sprocket drive then an outboard bearing is necessary.

CUSTOM BUILT PUMPS DIFFERENT FROM STANDARD PARTS SHOWN BELOW ARE MORE EXPENSIVE

Pat Number	Shaft	Left Port and Right Port	Port Location	Rotation	Max. Speed RPM	Max. Pressure PSI	Gallons Output & Horsepower Required at 2000 PSI			
							1200 RPM		1800 RPM	
							GPM OutPut	HP InPut	GPM OutPut	HP Input
2 BOLT TYPE B 4" ROUND PILOT 5-3/4" BOLT CIRCLE CODE 97										
P30A397BEIJ10-30	7/8 RD	16P12P	Side	CW	2400	2500	9.0	11.0	14.0	16.0
P30A397GUAB10-30	7/8 RD	20S16S	Rear	CW	2400	2500	9.0	11.0	14.0	16.0
P30A397HUAB10-25	7/8 SPL	16S20S	Rear	CCW	2400	2500	9.0	11.0	14.0	16.0
P30A397HUAB12-30	7/8 RD	16S20S	Rear	CCW	2400	2500	11.0	13.0	16.0	19.0
P30A397GUAB12-25	7/8 SPL	20S16S	Rear	CW	2400	2500	11.0	13.0	16.0	19.0
P30A397BEYF15-30	7/8 RD	16P16P	Side	Both	2400	2000	14.0	16.0	21.0	24.0
P30A397BEYJ15-25	7/8 SPL	20P16P	Side	CW	2400	2000	14.0	16.0	21.0	24.0
P30A397BEYG17-30	7/8 RD	16P20P	Side	CCW	2400	2000	16.0	19.0	24.0	28.0
P30A397BEYL20-30	7/8 RD	20P20P	Side	Both	2400	2000	18.0	21.0	27.0	32.0
2 BOLT TYPE B 4" ROUND PILOT 5-3/4" BOLT CIRCLE CODE 97										
P20A397BEIG10-30	7/8 RD	12P16P	Side	CCW	2400	3000	9.0	11.0	14.0	16.0
P20A397BEIG12-25	7/8 SPL	12P16P	Side	CCW	2400	3000	11.0	13.0	16.0	19.0
P20A397BEYG15-30	7/8 RD	16P20P	Side	CCW	2400	3000	14.0	16.0	21.0	24.0
P20A397BEYL20-30	7/8 RD	20P20P	Side	Both	2400	2500	18.0	21.0	27.0	32.0
P30A397MEAB07-25	7/8 SPL	12P12P	Rear	Both	2400	2500	7.0	8.0	11.0	13.0
P30A397BEIJ10-30	7/8 RD	16P12P	Side	CW	2400	2500	9.0	11.0	14.0	16.0
P30A397GUAB15-30	7/8 RD	20S16S	Rear	CW	2400	2000	14.0	16.0	21.0	24.0
P30A397HUAB15-25	7/8 SPL	16S20S	Rear	CCW	2400	2000	14.0	16.0	21.0	24.0
P30A397BEYG20-30	7/8 RD	16P20P	Side	CCW	2400	2000	18.0	21.0	27.0	32.0
P30A397BEYL20-25	7/8 SPL	20P20P	Side	Both	2400	2000	18.0	21.0	27.0	32.0
2 BOLT TYPE C 5" ROUND PILOT 7-1/8" BOLT CIRCLE CODE 98										
25X398BEIS15-11	1-1/4 RD	20P16P	Side	CW	2400	2000	18.0	21.0	27.0	32.0
25X398BEIS17-11	1-1/4 RD	20P16P	Side	CW	2400	2000	21.0	24.5	31.5	36.8
P50A398BEYG15-11	1-1/4 RD	16P20P	Side	CCW	2400	2500	18.0	21.0	27.5	32.1
P50A398BEYL20-11	1-1/4 RD	20P20P	Side	Both	2400	2000	24.0	28.0	37.5	43.8
P50A398BEYL22-7	1-1/4 SPL	20P20P	Side	Both	2400	2000	27.0	31.5	42.0	49.0
P50A398BEYL22-11	1-1/4 RD	20P20P	Side	Both	2400	2000	27.0	31.5	42.0	49.0
P75A698BEOV20-7	1-1/4 SPL	32SF24S	Side	CW	2400	2000	37.0	43.0	59.0	68.8
P75A698BEOV22-7	1-1/4 SPL	32SF24S	Side	CW	2400	2000	42.0	49.0	66.0	77.0
4 BOLT TYPE B 4" ROUND PILOT 5" BOLT CIRCLE CODE 42										
P20A342MEAB05-25	7/8 SPL	12P12P	Rear	Both	2400	3000	4.0	5.0	6.0	7.0
P20A342MEAB07-25	7/8 SPL	12P12P	Rear	Both	2400	3000	7.0	8.0	11.0	13.0
P20A342MEAB07-30	7/8 RD	12P12P	Rear	Both	2400	3000	7.0	8.0	11.0	13.0
P20A342BEIG10-25	7/8 SPL	12P16P	Side	CCW	2400	3000	9.0	11.0	14.0	16.0
P20A342BEIG12-30	7/8 RD	12P16P	Side	CCW	2400	3000	11.0	13.0	16.0	19.0
P20A342BEYG15-25	7/8 SPL	16P20P	Side	CCW	2400	3000	14.0	16.0	21.0	24.0
P20A342BEYG17-30	7/8 RD	16P20P	Side	CCW	2400	2500	16.0	19.0	24.0	28.0
P20A342BEYG17-25	7/8 SPL	16P20P	Side	CCW	2400	2500	16.0	19.0	24.0	28.0
P20A342BEYL20-25	7/8 SPL	20P20P	Side	Both	2400	2500	18.0	21.0	27.0	32.0
P30A342MEAB07-30	7/8 RD	12P12P	Side	Both	2400	2500	7.0	8.0	11.0	13.0
P30A342BEIG10-30	7/8 RD	12P16P	Side	CCW	2400	2000	14.0	16.0	21.0	24.0
P30A342BEIG12-30	7/8 RD	12P16P	Side	CCW	2400	2000	16.0	19.0	24.0	28.0
P30A342BEYJ15-25	7/8 SPL	20P16P	Side	CW	2400	2000	16.0	19.0	24.0	28.0
P30A342GUAB17-30	7/8 RD	20S16S	Rear	CW	2400	2000	16.0	19.0	24.0	28.0
P30A342BEYG17-25	7/8 SPL	16P20P	Side	CCW	2400	2000	18.0	21.0	27.0	32.0
P30A397HUAB20-25	7/8 SPL	16S20S	Rear	CCW	2400	2000	18.0	21.0	27.0	32.0
P30A342BEYL20-30	7/8 RD	20P20P	Side	Both	2400	2000	18.0	21.0	27.0	32.0
25X342BEIT20-25	7/8 SPL	20P20P	Side	Both	2400	2000	24.0	28.0	36.0	42.0
25X342BEIZ22-30	7/8 RD	24P20P	Side	CW	2400	2000	27.0	31.5	40.5	47.3
25X342BEIZ25-25	7/8 SPL	24P20P	Side	CW	2400	2000	30.0	35.0	45.0	52.5
P50A342BEYG17-25	7/8 SPL	16P20P	Side	CCW	2400	2000	21.0	24.5	32.5	37.9
4 BOLT TYPE C 5" ROUND 6-3/16" BOLT CIRCLE CODE 78										
P50A378BEYP25-7	1-1/4 SPL	24P20P	Side	CW	2400	2000	30.0	35.0	47.0	54.8
P75A378BEAP25-7	1-1/4 SPL	24S20S	Side	CW	2400	2000	48.0	56.0	74.0	86.3
P75A378BEAM30-7	1-1/4 SPL	20S24S	Side	CCW	2400	2000	58.0	58.0	90.0	105.0

COMMERCIAL MULTIPLE PUMPS
We Can Make Any Commercial Tandem Pump

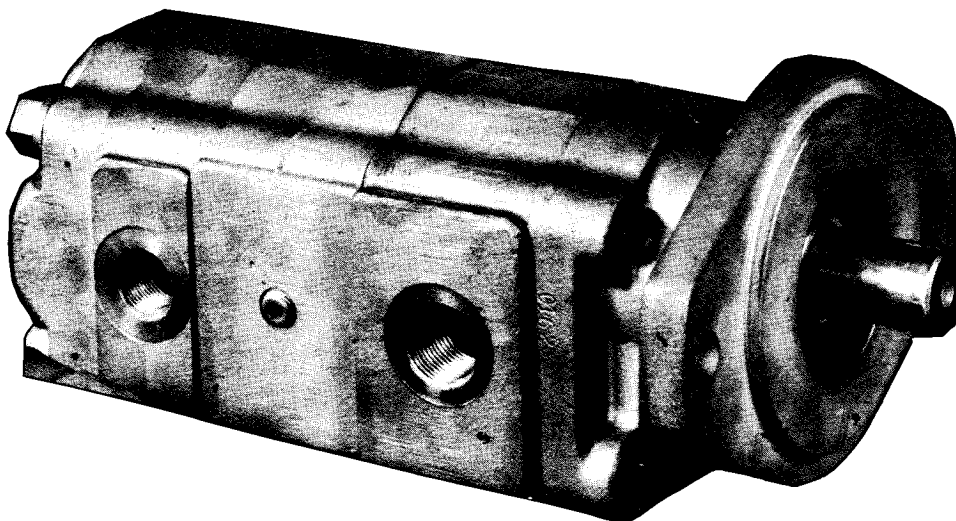

FOR ALL UNITS

To determine direction of shaft rotation, view the unit with the shaft pointing toward you, and the idler (driven) gear beneath the shaft. With clockwise rotation, flow will be left to right. The inlet port will be on the left, outlet on the right. The flow is in the opposite direction with counter-clockwise rotation. Inverting the pump will reverse the inlet and outlet ports but not the direction of rotation.

On all pumps direct drive is best. When using direct drive an outboard bearing is not necessary. If there is any side load on the pump due to a driveline or belt pulley or chain sprocket drive then an outboard bearing is necessary.

MULTIPLE UNITS

Each section of a multiple pump should be regarded as a single pumping unit with corresponding delivery and power input requirements. Since the entire input is fed through the drive shaft, the power delivered to or from the pump is limited by the physical strength of the shaft. To define this power limitation, we use a "PL" factor, "P" being the operating pressure and "L" the summation of gear widths.

In multiple pumps, the "PL" must be calculated for the first connecting shaft as well as the drive shaft. Each style or type of shaft has a unique "PL" factor as noted in the table below.

Pressure x total gear width = PL
PL MUST NOT EXCEED NUMBER SHOWN
IN CHART FOR APPROPRIATE SHAFT.

Pump	Shaft Style	PL
P30	SAE A Spline	2,700
	SAE B Spline	8,300
	6 Tooth Spline	11,650
	.875 Key	5,700
	1.00 Key	8,600
	Connecting Shaft	5,500
	Continental Shaft	5,500
P50	SAE B Spline	6,400
	SAE C Spline	13,850
	1.00 Key	6,600
	1.25 Key	13,000
	Connecting Shaft	8,000
	Continental Shaft	8,000
P75	SAE C Spline (Single)	8,600
	SAE C Spline (Multiple)	12,000
	1.25 Key	8,300
	Connecting Shaft	9,450
	Continental Shaft	7,750

MULTIPLE UNITS

Multiple units are coded in the same manner as single units except that additional designations for added sub-components must be included. Each section added to the single assembly requires a proper code for a bearing carrier, gear housing, and connecting shaft. The letter "B" designates a multiple unit. Here is an example of an assembly code for a two section P75 pump:

When specifying split flange porting on multiple units, all coding MUST be cleared by our Technical Service Department.

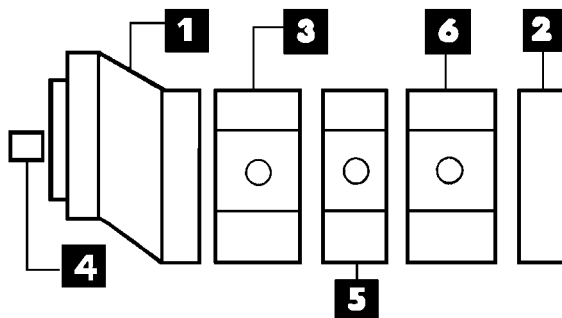

P75 MULTIPLE PUMP

Assembly Code P75B 178 BI OK15-7 C OK12-1

Pump Series Model	P 75 B	1. Shaft End Cover	178
		2. Port End Cover	BI
		3. Gear Housing	OK15
		4. Drive Shaft	7
		5. Bearing Carrier	C
		6. Gear Housing	OK12
		7. Connecting Shaft	1

**COMMERCIAL TANDEM ROLLER BEARING PUMPS
WITH ONE PIECE SHAFTS & GEARS**

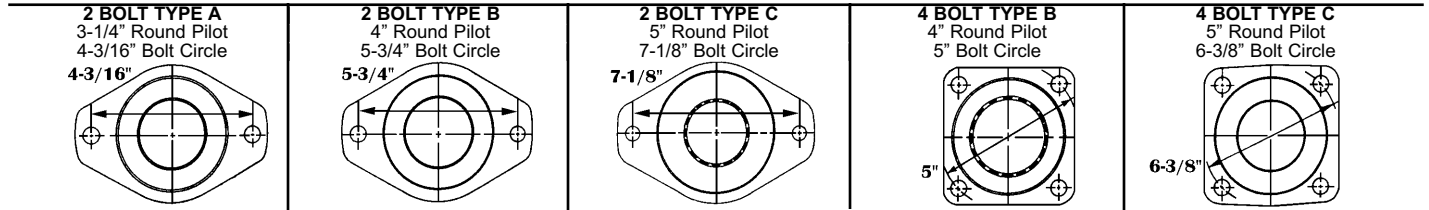
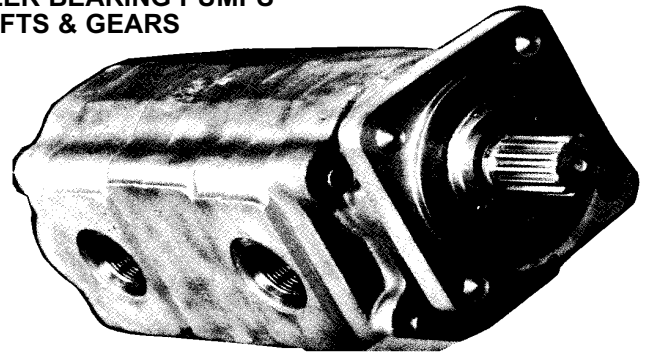

Pumps in this series are positive displacement type used to produce a flow of hydraulic fluid. Flow rate depends on the pump size, the speed at which it is driven and the resistance or pressure it is pumping against.

Pump ratings in GPM at 1200 PRM and at 2000 PSI. For ratings at other speeds refer to the application chart below.

We stock Pumps, Repair Parts, Seal Kits, Shafts, Bearings & Foot Mounts.

TO CHANGE ROTATION on double pumps with ports in housing, rotate housing 180° & rotate both wear plates 180° taking care not to lose the very small pocket seals in the wear plates. Also rotate the bearing carrier 180°. If pump does not have 2 check valves, move plug from one side to the other in the shaft end cover.

ROTATION IS RIGHT HAND CLOCKWISE FACING SHAFT END

FOR ALL UNITS

To determine direction of shaft rotation, view the unit with the shaft pointing toward you, and the idler (driven) gear beneath the shaft. With clockwise rotation, flow will be left to right. The inlet port will be on the left, outlet on the right. The flow is in the opposite direction with counter-clockwise rotation. Inverting the pump will reverse the inlet and outlet ports but not the direction of rotation.

Pump with 7/8"-13 Spline Shaft 2 2 Bolt B Flange Mount Number	Gallons Output & Horsepower Required at 1000 PSI											
	1200 RPM		Shaft End Pump 1800 RPM		2400 RPM		1200 RPM		Cover End Pump 1800 RPM		2400 RPM	
	GPM OutPut	HP InPut	GPM OutPut	HP InPut	GPM OutPut	HP InPut	GPM OutPut	HP InPut	GPM OutPut	HP InPut	GPM OutPut	HP InPut
P20B697LIAB05-25VXAB05-1	4.5	5.3	7.0	8.2	9.5	11.1	4.5	5.3	7.0	8.2	9.5	11.1
P20B697LIAB07-25VXAB05-1	7.0	8.2	10.7	12.5	14.5	16.9	4.5	5.3	7.0	8.2	9.5	11.1
P20B697LIJ10-25CAB07-1	9.0	10.5	14.0	16.3	19.0	22.2	7.0	8.2	10.7	12.5	14.5	16.9
P20B697BIIF12-25CIF10-1	11.5	13.4	18.0	21.0	24.0	28.0	9.0	10.5	14.0	16.3	19.0	22.2
P20B697BIYF15-25CIIF12-1	14.0	16.3	21.5	25.1	29.0	33.8	11.5	13.4	18.0	21.0	24.0	28.0
P20B697BIYF17-25CPYF15-1	16.0	18.7	25.0	29.2	34.0	39.7	14.0	16.3	21.5	25.1	29.0	33.8
P20B697BIYL20-25CYFF17-1	18.5	21.6	29.0	33.8	39.0	45.5	16.0	18.7	25.0	29.2	34.0	39.7
P30B697LIAB05-25VXAB05-1	4.5	5.3	7.0	8.2	9.5	11.1	4.5	5.3	7.0	8.2	9.5	11.1
P30B697LIAB07-25VXAB05-1	7.0	8.2	10.7	12.5	14.5	16.9	4.5	5.3	7.0	8.2	9.5	11.1
P30B697LIJ10-25CAB07-1	9.0	10.5	14.0	16.3	19.0	22.2	7.0	8.2	10.7	12.5	14.5	16.9
P30B697BIIF12-25CIF10-1	11.5	13.4	18.0	21.0	24.0	28.0	9.0	10.5	14.0	16.3	19.0	22.2
P30B697BIYF15-25CIIF12-1	14.0	16.3	21.5	25.1	29.0	33.8	11.5	13.4	18.0	21.0	24.0	28.0
P30B697BIYF17-25CPYF15-1	16.0	18.7	25.0	29.2	34.0	39.7	14.0	16.3	21.5	25.1	29.0	33.8
P30B697BIYL20-25CYFF17-1	18.5	21.6	29.0	33.8	39.0	45.5	16.0	18.7	25.0	29.2	34.0	39.7
P25X397CEAB05-25BHAB05-1	6.0	7.0	9.0	10.5	12.5	14.6	6.0	7.0	9.0	10.5	12.5	14.6
P25X397CEAB07-25BHAB05-1	9.0	10.5	13.7	15.9	18.5	21.6	6.0	7.0	9.0	10.5	12.5	14.6
P25X397CEAB10-25BHAB07-1	12.0	14.0	18.0	21.0	25.0	29.2	9.0	10.5	13.7	15.9	18.5	21.6
P25X397CEIL12-25DAB10-1	15.0	17.5	23.0	26.8	31.0	36.2	12.0	14.0	18.0	21.0	25.0	29.2
P25X397BIIL15-25CIL12-1	18.0	21.0	27.5	32.1	37.0	43.2	15.0	17.5	23.0	26.8	31.0	36.2
P25X397BYIT17-25CIT15-1	21.0	24.5	32.5	37.9	44.0	51.3	18.0	21.0	27.5	32.1	37.0	43.2
P25X378BYJC20-25CIT17-1	24.0	28.0	37.5	43.8	51.0	59.5	21.0	24.5	32.5	37.9	44.0	51.3
P25X378BYJC22-25CIT20-1	27.0	31.5	42.0	49.0	57.0	66.5	24.0	28.0	37.5	43.8	51.0	59.5
P25X378BYJC25-25CJC22-1	30.0	36.2	47.0	54.8	63.5	74.1	27.0	31.5	42.0	49.0	57.0	66.5
2 Bolt C 1-1/4"-14 Splined Shaft												
P50B698BIIF10-7CEAB07-1	12.0	14.0	18.0	21.0	25.0	29.2	9.0	10.5	13.7	16.0	18.5	21.6
P50B698BIYF12-7CIF10-1	15.0	17.5	23.0	26.8	31.0	36.2	12.0	14.0	18.0	21.0	25.0	29.2
P50B698BIYF15-7CIYF12-1	18.0	21.0	27.5	32.1	37.0	43.2	15.0	17.5	23.0	26.8	31.0	36.2
P50B698BIYL17-7CIYF15-1	21.0	24.5	32.5	37.9	44.0	51.3	18.0	21.0	27.5	32.1	37.0	43.2
P50B698BIYL20-7CIYL17-1	24.0	28.0	37.5	43.8	51.0	59.5	21.0	24.5	32.5	37.9	44.0	51.3
P50B698BIYL22-7CIYL20-1	27.0	31.5	42.0	49.0	57.0	66.5	24.0	28.0	37.5	43.8	51.0	59.5
P50B698BIYP25-7CIYL22-1	30.0	35.0	47.0	54.8	63.5	74.1	27.0	31.5	42.0	49.0	57.0	66.5
4 Bolt C 1-1/4"-14 Splined Shaft												
P75B678BIUJ07-7CUJ07-1	13.5	15.8	21.7	25.3	29.7	34.7	13.5	15.8	21.7	25.3	29.7	34.7
P75B678BIOF10-7CUJ07-1	17.0	19.8	27.5	32.1	38.0	44.3	13.5	15.8	21.7	25.3	29.7	34.7
P75B678BIOL12-7COF10-1	22.0	25.7	35.5	41.4	49.0	57.2	17.0	19.8	27.5	32.1	38.0	44.3
P75B678BIOP15-7COL12-1	27.0	31.5	43.5	50.8	59.5	69.4	22.0	25.7	35.5	41.4	49.0	57.2
P75B678BIOQ17-7COP15-1	32.0	37.3	51.0	59.5	70.0	81.7	27.0	31.5	43.5	50.8	59.5	69.4
P75B678BIOQ20-7COQ17-1	37.5	43.8	59.0	68.8	80.0	93.3	32.0	37.3	51.0	59.5	70.0	81.7
P75B678BIOV22-7COQ20-1	42.0	49.0	66.0	77.0	90.0	105.0	37.5	43.8	59.0	68.8	80.0	93.3
P75B678BIOV25-7COV22-1	48.0	56.0	74.0	86.3	101.0	117.9	42.0	49.0	66.0	77.0	90.0	105.0
P75B678BIOV27-7COV25-1	52.5	61.3	81.5	95.1	111.0	129.5	48.0	56.0	74.0	86.3	101.0	117.9
P75B678BIOV30-7COW27-1	58.0	67.7	90.0	105.0	122.0	142.4	52.5	61.3	81.5	95.1	111.0	129.5

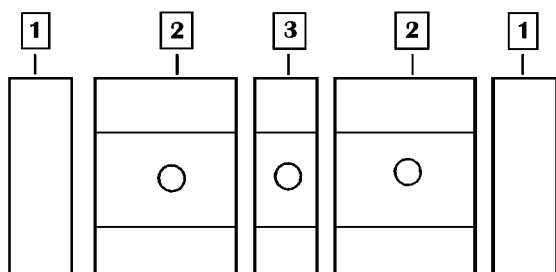
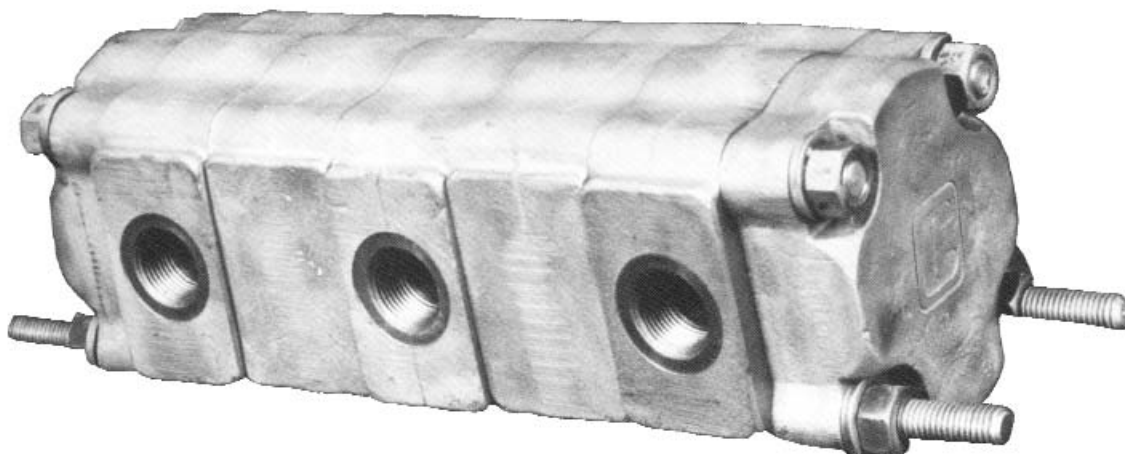

- 1. PORT END COVER
- 2. GEAR HOUSING
- 3. BEARING CARRIER

Commercial's rotary flow dividers/pressure intensifiers are extremely versatile components which, when properly applied, will save on installation and operating costs, increase circuit versatility, offer convenience, and improve pump life. Models P30, P50, and P75 which are assembled from standard heavy-duty gear pump components available throughout the world. Ideal applications are:

1. As flow equalizers to synchronize the operation of multiple cylinders or motors.
2. As flow dividers to distribute the pump flow according to the requirements of each system.
3. As pressure intensifiers to increase the pressure available to a particular system beyond the pump's relief valve setting or to reduce the time at which the pump must operate at maximum pressure.

Rotary flow dividers/pressure intensifiers offer advantages often overlooked when designing a hydraulic circuit. They are unique components which can be considered to "float" in the hydraulic circuit, working only when required, and then, only to the extent necessary. Unlike variable orifice types, rotary flow dividers operate on the principle that fluid horsepower input equals fluid horsepower output, less, of course, the small efficiency loss of the unit. If the pressure at an outlet port is lower than the inlet pressure, the low pressure section of the rotary flow divider acts as a motor. The energy expended across the motor is not wasted in generating heat but is applied through the interconnecting shaft to do work in the other sections.

The total output flow is equal to the input flow. Each section's output is in proportion to the gear width of the section. As a flow equalizer, each section has equal gear widths.

Rotary flow dividers operate automatically. No pilot signals or other devices are necessary to initiate their operation.

The economic advantages of rotary flow dividers/pressure intensifiers is best illustrated by the components they eliminate. Expensive multi-drive gear boxes, multiple pumps, and extensive plumbing and fittings can be replaced by a single pump and a flow divider remotely mounted in any convenient location. Problems, common in feeding multiple pumps, are eliminated because flow dividers are pressure-charged. Rotary flow dividers can be mounted in any position and, because they are self-lubricating, require no maintenance. No external drain lines or shafts are required. Extended studs are provided for easy mounting.

PORTING

Standard porting of the P30, P50, and P75 flow dividers is through the gear housing or bearing carrier. Porting through the port end covers is available on special request.

Two studs extend from each end of the flow divider for easy mounting.

Part Number	Min. Inlet GPM	Max. Inlet GPM	Max. PSI	Outlet Ratio
FD30BBYIJ10-1EID10BY	9.0	19.5	2500	50:50
FD30BBYIJ12-1EID12BY	11.5	24.9	2500	50:50
FD30BBYYJ15-1EYD15BY	14.0	30.3	2500	50:50
FD30BBYYJ17-1EYD17BY	16.3	34.7	2000	50:50
FD30BBYYJ20-1EYD20BY	18.6	40.1	2000	50:50
FD50BBYIJ10-1EID10BY	11.6	26.0	2500	50:50
FD50BBYIJ12-1EID12BY	15.1	32.5	2500	50:50
FD50BBYYJ15-1EYD15BY	18.6	39.0	2500	50:50
FD50BBYYJ17-1EYD17BY	22.1	45.5	2000	50:50
FD50BBYYK20-1EYD20BY	25.6	52.0	2000	50:50
FD50BBYYK22-1EYD22BY	29.1	58.5	2000	50:50
FD50BBYYK25-1EYD25BY	32.6	65.0	2000	50:50
FD75BBYIJ10-1EID10BY	14.0	36.8	2500	50:50
FD75BBYIJ12-1EID12BY	21.0	47.7	2500	50:50
FD75BBYYJ15-1EID15BY	26.8	58.5	2500	50:50
FD75BBYYJ17-1EYD17BY	31.5	69.3	2500	50:50
FD75BBYYJ20-1EYD20BY	38.5	81.3	2500	50:50
FD75BBYQ22-1EOB22BY	43.1	91.0	2250	50:50
FD75BBYQ25-1EOB25BY	49.0	104.0	2250	50:50
FD75BBYQ27-1EOB27BY	53.6	113.8	2000	50:50
FD75BBYQ30-1EOB30BY	60.6	125.7	2000	50:50
FD30BBYYJ15-1GRAB05BY	9.0	19.5	2500	78:22
FD30BBYYJ20-1EID10BY	14.0	30.3	2000	67:33
FD50BBYYJ15-1GRAB05BY	11.6	26.0	2500	75:25
FD50BBYYK20-1EID10BY	18.6	39.0	2000	67:33
FD50BBYYK25-1EID10BY	22.1	45.5	2000	71:29
FD75BBYOK17-1EUD07BY	21.0	46.6	2500	74:26
FD75BBYOP22-1EOD10BY	28.5	63.9	2250	71:29
FD75BBYOP30-1EOD12BY	40.8	86.7	2000	73:28

COMMERCIAL HIGH PERFORMANCE GEAR PUMPS WITH ROLLER BEARINGS CUSTOM BUILT PUMPS

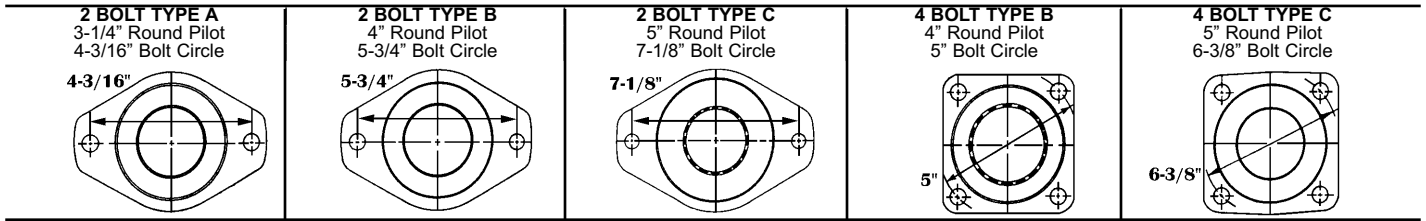

FOR ALL UNITS

To determine direction of shaft rotation, view the unit with the shaft pointing toward you, and the idler (driven) gear beneath the shaft. With clockwise rotation, flow will be left to right. The inlet port will be on the left, outlet on the right. The flow is in the opposite direction with counter-clockwise rotation. Inverting the pump will reverse the inlet and outlet ports but not the direction of rotation.

TO CHANGE ROTATION on pumps with ports in housing, rotate housing 180° & rotate both wear plates 180° taking care not to lose the very small pocket seals in the wear plates. If pump does not have 2 check valves, move plug from one side to the other in the shaft end cover.

Pumps in this series are positive displacement type used to produce a flow of hydraulic fluid. Flow rate depends on the pump size, the speed at which it is driven and the resistance or pressure it is pumping against.

CUSTOM BUILT PUMPS BUILT FROM PARTS ARE NON-RETURNABLE



Gallons Output & Horsepower Required at 2000 PSI

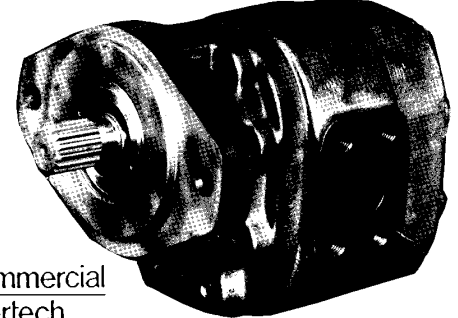

Pump Series Gear Width	CIPR	Max. Bearing Carrier Flow		Max. Speed RPM	*Max. Pres-ure PSI*	1200 RPM		1800 RPM		2400 RPM	
		Inlet	Pressure			GPM OutPut	HP InPut	GPM OutPut	HP InPut	GPM OutPut	HP InPut
P51 SERIES CAST IRON ROLLER BEARING PUMPS											
P51-1"	2.55	21	40	2400	3000	12.0	15.90	18.0	23.90	25.0	33.25
P51-1-1/4"	3.19	21	40	2400	3000	15.0	20.00	23.0	30.60	31.0	41.20
P51-1-1/2"	3.82	21	40	2400	3000	18.0	23.90	27.5	36.57	37.0	49.20
P51-1-3/4"	4.46	21	40	2400	3000	21.0	27.93	32.5	43.22	44.0	58.50
P51-2"	5.10	21	40	2400	2500	24.0	31.90	37.5	49.87	51.0	67.80
P51-2-1/4"	5.73	21	40	2400	2500	27.0	36.00	42.0	55.86	57.0	75.80
P51-2-1/2"	6.37	21	40	2400	2500	30.0	40.00	47.0	62.50	63.5	84.50
P350 SERIES CAST IRON BUSHING PUMPS											
P350-1"	2.55	54	54	2400	3500	11.5	15.90	17.5	23.90	24.5	33.25
P350-1-1/4"	3.19	54	54	2400	3500	15.0	20.00	23.0	30.60	31.0	41.20
P350-1-1/2"	3.82	54	54	2400	3500	18.0	23.90	27.5	36.57	37.0	49.20
P350-1-3/4"	4.46	54	54	2400	3250	21.0	27.93	32.5	43.22	44.0	58.50
P350-2"	5.10	54	54	2400	3000	24.0	31.90	37.5	49.90	51.0	67.80
P350-2-1/4"	5.73	54	54	2400	2750	27.0	36.00	42.0	59.00	57.0	75.80
P350-2-1/2"	6.37	54	54	2400	2500	30.0	40.00	47.0	62.50	63.5	84.50
P37X SERIES CAST IRON ROLLER BEARING PUMPS											
P37X-1"	3.00	31	60	2400	2000	12.5	16.62	20.0	26.60	24.0	32.00
P37X-1-1/4"	3.75	31	60	2400	2000	16.5	21.94	26.0	34.58	31.0	41.20
P37X-1-1/2"	4.50	31	60	2400	2000	20.0	26.60	31.5	41.90	37.5	49.88
P37X-1-1/34"	5.25	31	60	2400	2000	24.0	32.00	37.5	49.88	44.5	59.20
P37X-2"	6.00	31	60	2400	2000	28.0	37.25	43.5	57.86	51.0	67.83
P37X-2-1/4"	6.75	31	60	2400	2000	31.5	41.90	49.5	65.84	58.0	77.14
P37X-2-1/2"	7.50	31	60	2400	2000	35.5	47.22	55.0	73.15	64.5	85.79
P37X-3"	9.00	31	60	2400	2000	43.0	57.20	66.5	88.45	78.0	103.75
P365 SERIES CAST IRON BUSHING PUMPS											
P365-1"	3.60			2400	3500	15.5	20.65	24.5	32.60	34.0	45.30
P365-1-1/4"	4.50			2400	3500	20.0	26.60	31.5	42.00	43.0	57.20
P365-1-1/2"	5.40	These are NON-STOCK Special Order Only		2400	3500	24.5	32.25	38.0	50.60	52.5	70.00
P365-1-3/4"	6.30		2400	3500	29.0	38.60	45.5	60.50	62.0	82.50	
P365-2"	7.20		2400	3500	33.5	44.60	52.0	69.20	71.0	94.50	
P365-2-1/4"	8.10		2400	3250	38.0	50.60	59.0	78.50	80.5	107.00	
P365-2-1/2"	9.00		2400	3500	43.0	57.50	66.0	88.00	90.0	120.00	
P75 SERIES CAST IRON ROLLER BEARING PUMPS											
P75-1"	4.10	35	70	2400	2500	17.0	22.60	27.5	36.60	38.0	50.60
P75-1-1/4"	5.125	35	70	2400	2500	22.0	29.25	35.5	47.20	49.0	65.20
P75-1-1/2"	6.15	35	70	2400	2500	27.0	36.00	43.5	57.90	59.5	79.20
P75-1-3/4"	7.175	35	70	2400	2500	32.0	42.60	51.0	68.00	70.0	93.10
P75-2"	8.20	35	70	2400	2500	37.5	49.90	59.0	78.50	80.0	106.50
P75-2-1/4"	9.225	35	70	2400	2250	42.0	59.90	66.0	88.00	90.0	120.00
P75-2-1/2"	10.25	35	70	2400	2250	48.0	64.00	74.0	98.50	101.0	134.50
P75-2-3/4"	11.275	35	70	2400	2000	52.5	69.80	81.5	108.40	111.0	147.70
P75-3"	12.30	35	70	2400	2000	58.0	77.15	90.0	120.00	122.0	162.30
P76 SERIES CAST IRON ROLLER BEARING PUMPS											
P76-1"	4.10	35	70	2400	3000	17.0	22.60	27.5	36.60	38.0	50.60
P76-1-1/4"	5.125	35	70	2400	3000	22.0	29.25	35.5	47.20	49.0	65.20
P76-1-1/2"	6.15	35	70	2400	3000	27.0	36.00	43.5	57.90	59.5	79.20
P76-1-3/4"	7.175	35	70	2400	3000	32.0	42.60	51.0	68.00	70.0	93.10
P76-2"	8.20	35	70	2400	2500	37.5	49.90	59.0	78.50	80.0	106.50
P76-2-1/4"	9.225	35	70	2400	2250	42.0	59.90	66.0	88.00	90.0	120.00
P76-2-1/2"	10.25	35	70	2400	2250	48.0	64.00	74.0	98.50	101.0	134.50
P76-2-3/4"	11.275	35	70	2400	2000	52.5	69.80	81.5	108.50	111.0	148.00
P76-3"	12.30	35	70	2400	2000	58.0	77.20	90.0	120.00	122.0	162.50

* MAXIMUM INTERMITTENT PEAK PRESSURE RATING - SUBTRACT APPROXIMATELY 500 PSI FOR CONSTANT PSI RATING.

**COMMERCIAL HIGH PERFORMANCE GEAR PUMPS WITH ROLLER BEARINGS
CUSTOM BUILT PUMPS**

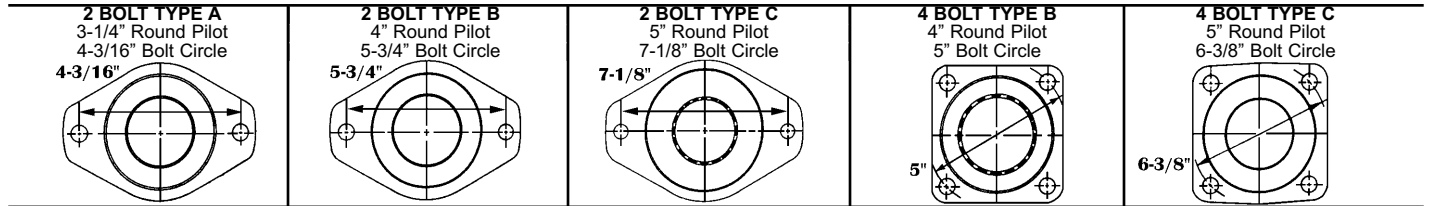

Pump Series	Gear Width	CIPR	O-Ring Thread Ports		Max. Speed RPM	*Max. Pressure PSI*	Gallons Output & Horsepower Required at 2000 PSI					
			Inlet	Outlet			1200 RPM		1800 RPM		2400 RPM	
							GPM	HP	GPM	HP	GPM	HP
							OutPut	InPut	OutPut	InPut	OutPut	InPut
P5 SERIES ALUMINUM HOUSING BUSHING PUMPS												
P5-3CC	.18		1-1/16	7/8	4000	4400	.8	1.1	1.3	1.7	1.8	2.2
P5-6CC	.37		1-1/16	7/8	3600	4400	1.7	2.3	2.6	3.4	3.6	4.6
P5-8CC	.49		1-1/16	7/8	3000	4400	2.3	3.0	3.5	4.5	4.8	6.0
P5-10CC	.61		1-1/16	7/8	2800	4000	2.8	3.7	4.3	5.6	5.9	7.5
P11 SERIES ALUMINUM HOUSING BUSHING PUMPS												
P11-8CC	.49		1-5/16	1-1/16	4000	4400	2.3	3.0	3.5	4.5	4.7	6.0
P11-11CC	.67		1-5/16	1-1/16	3600	4400	3.2	4.1	4.8	6.2	6.5	8.2
P11-16CC	.98		1-5/16	1-1/16	3000	4400	4.6	6.0	6.9	9.0	9.5	12.2
P11-23CC	1.40		1-5/16	1-1/16	2800	3700	6.5	8.5	10.9	14.2	13.5	17.4
P11-31CC	1.89		1-5/16	1-1/16	2300	3150	9.0	12.0	13.5	18.0	18.2	24.0
P17 SERIES ALUMINUM HOUSING BUSHING PUMPS												
P17-19CC	1.16		1-5/8	1-5/16	3300	4000	5.4	7.05	8.1	10.4	10.9	14.0
P17-25CC	1.53		1-5/8	1-5/16	3100	4000	7.1	9.3	10.7	13.9	14.3	18.5
P17-33CC	2.02		1-5/8	1-5/16	3000	4000	9.4	12.25	14.1	18.4	18.9	24.5
P17-38CC	2.32		1-5/8	1-5/16	3000	4000	10.8	14.0	16.3	21.2	22.4	29.0
P17-52CC	3.17		1-5/8	1-5/16	2600	3200	14.8	19.2	22.3	28.8	30.6	39.5
P315 SERIES CAST IRON BUSHING PUMPS												
P315-1/2"	.63				3000	3500	3.0	4.0	4.5	6.0	6.0	8.0
P315-3/4"	.94				3000	3500	4.5	6.0	6.8	9.0	9.0	12.0
P315-1"	1.25				3000	3500	6.0	8.0	9.0	12.0	12.0	16.0
P315-1-1/4"	1.56				3000	3500	7.5	10.0	11.3	15.0	15.0	20.0
P315-1-1/2"	1.88				3000	3500	9.0	12.0	13.5	18.0	18.0	24.0
P315-1-3/4"	2.19				3000	2750	10.5	14.0	15.8	21.0	21.0	28.0
P315-2"	2.50				3000	2500	12.0	16.0	18.0	24.0	24.0	32.0
P30 SERIES CAST IRON ROLLER BEARING PUMPS												
P30-1"	1.97	21	40		2400	2500	9.0	12.00	14.0	18.62	19.0	25.25
P30-1-1/4"	2.46	21	40		2400	2500	11.5	15.30	18.0	23.90	24.0	32.00
P30-1-1/2"	2.96	21	40		2400	2500	14.0	18.62	21.5	28.60	29.0	38.57
P30-1-3/4"	3.45	21	40		2400	2250	16.0	21.00	25.0	32.82	34.0	44.63
P30-2"	3.94	21	40		2400	2250	18.5	24.28	29.0	38.07	39.0	51.20
P20 SERIES CAST IRON ROLLER BEARING PUMPS												
P20-1/2"	.98	21	40		2400	3000	4.5	6.00	7.0	9.30	9.5	12.63
P20-3/4"	1.48	21	40		2400	3000	6.75	9.00	10.5	13.96	14.25	18.90
P20-1"	1.97	21	40		2400	3000	9.0	12.00	14.0	18.62	19.0	25.25
P20-1-1/4"	2.46	21	40		2400	3000	11.5	15.30	18.0	23.90	24.0	32.00
P20-1-1/2"	2.96	21	40		2400	3000	14.0	18.62	21.5	28.60	29.0	38.57
P20-1-3/4"	3.45	21	40		2400	2500	16.0	21.00	25.0	32.82	34.0	44.63
P20-2"	3.94	21	40		2400	2500	18.5	24.28	29.0	38.07	39.0	51.20
P31 SERIES CAST IRON ROLLER BEARING PUMPS												
P31-1"	1.97	21	40		2400	3000	9.0	12.00	14.0	18.62	19.0	25.25
P31-1-1/4"	2.46	21	40		2400	3000	11.5	15.30	18.0	23.90	24.0	32.00
P31-1-1/2"	2.96	21	40		2400	3000	14.0	18.62	21.5	28.60	29.0	38.57
P31-1-3/4"	3.45	21	40		2400	2500	16.0	21.00	25.0	32.82	34.0	44.63
P31-2"	3.94	21	40		2400	2500	18.5	24.28	29.0	38.07	39.0	51.20
P330 SERIES CAST IRON BUSHING PUMPS												
P330-1"	1.97	40	40		2400	3500	8.5	12.00	14.0	18.62	19.0	25.25
P330-1-1/4"	2.46	40	40		2400	3500	11.5	15.30	18.0	23.90	24.0	32.00
P330-1-1/2"	2.96	40	40		2400	3500	14.0	18.62	21.5	28.60	29.0	38.57
P330-1-3/4"	3.45	40	40		2400	3250	16.0	21.00	25.0	32.82	34.0	44.63
P330-2"	3.94	40	40		2400	3000	18.5	24.28	29.0	38.07	39.0	51.20
P25X SERIES CAST IRON ROLLER BEARING PUMPS												
P25X-1"	2.55	21	40		2400	2000	12.0	15.90	18.0	23.90	25.0	33.25
P25X-1-1/4"	3.19	21	40		2400	2000	15.0	20.00	23.0	30.60	31.0	41.20
P25X-1-1/2"	3.82	21	40		2400	2000	18.0	23.90	27.5	36.57	37.0	49.20
P25X-1-3/4"	4.46	21	40		2400	2000	21.0	27.93	32.5	44.22	44.0	58.50
P25X-2"	5.10	21	40		2400	2000	24.0	31.90	37.5	49.87	51.0	67.80
P25X-2-1/4"	5.73	21	40		2400	2000	27.0	36.00	42.0	55.86	57.0	75.80
P25X-2-1/2"	6.37	21	40		2400	2000	30.0	40.00	47.0	62.50	63.5	84.50
P50 SERIES CAST IRON ROLLER BEARING PUMPS												
P50-1"	2.55	21	50		2400	2500	12.0	15.90	18.0	23.90	25.0	33.25
P50-1-1/4"	3.19	21	50		2400	2500	15.0	20.00	23.0	30.60	31.0	41.20
P50-1-1/2"	3.82	21	50		2400	2500	18.0	23.90	27.5	36.57	37.0	49.20
P50-1-3/4"	4.46	21	50		2400	2000	21.0	27.93	32.5	43.22	44.0	58.50
P50-2"	5.10	21	50		2400	2000	24.0	31.90	37.5	49.87	51.0	67.80
P50-2-1/4"	5.73	21	50		2400	2000	27.0	36.00	42.0	55.86	57.0	75.80
P50-2-1/2"	6.37	21	50		2400	2000	30.0	40.00	47.0	62.50	63.5	84.50

* MAXIMUM INTERMITTENT PEAK PRESSURE RATING - SUBTRACT APPROXIMATELY 500 PSI FOR CONSTANT PSI RATING.

COMMERCIAL TANDEM BUSHING BEARING PUMPS WITH ONE PIECE SHAFT & GEARS

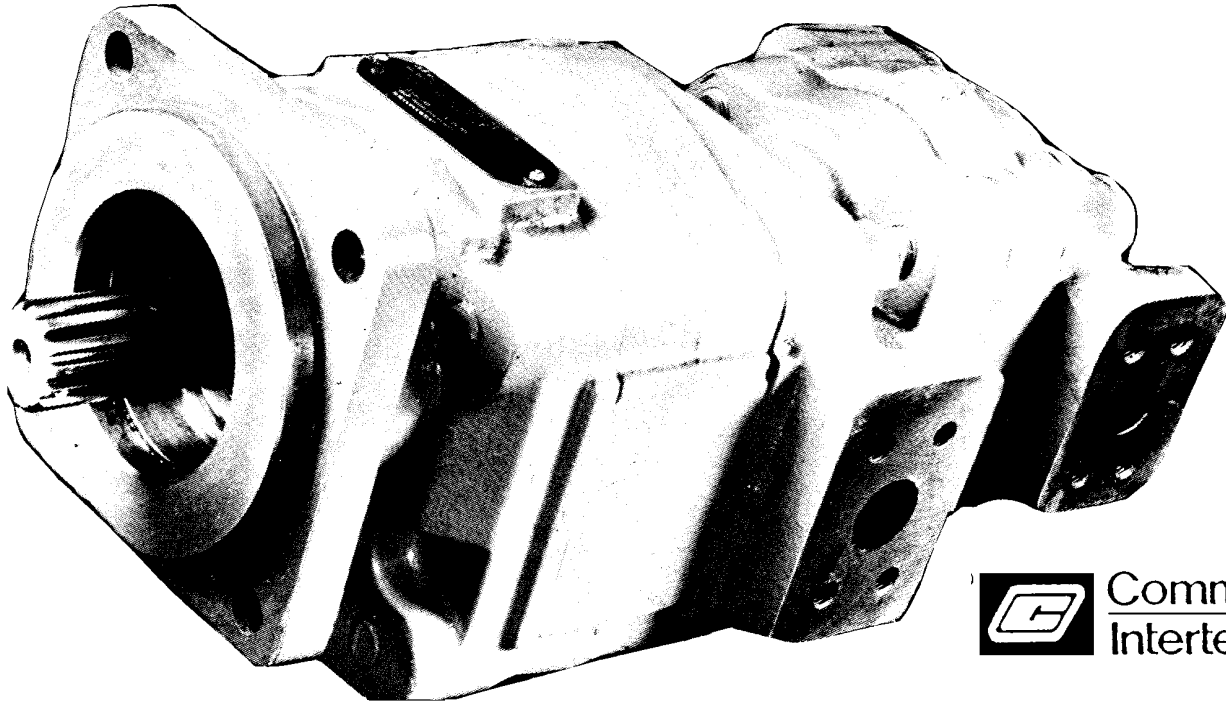

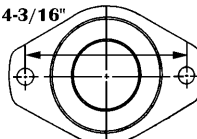
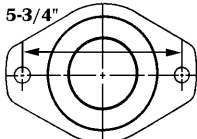
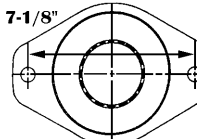
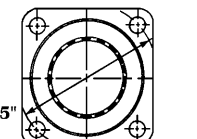
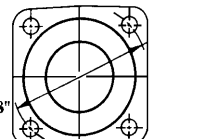
2 BOLT TYPE A 3-1/4" Round Pilot 4-3/16" Bolt Circle 	2 BOLT TYPE B 4" Round Pilot 5-3/4" Bolt Circle 	2 BOLT TYPE C 5" Round Pilot 7-1/8" Bolt Circle 	4 BOLT TYPE B 4" Round Pilot 5" Bolt Circle 	4 BOLT TYPE C 5" Round Pilot 6-3/8" Bolt Circle 
---------------------------------------------------------------------------------------------------------------------------------------------------------	----------------------------------------------------------------------------------------------------------------------------------------------------	----------------------------------------------------------------------------------------------------------------------------------------------------	--------------------------------------------------------------------------------------------------------------------------------------------------	------------------------------------------------------------------------------------------------------------------------------------------------------

Pumps in this series are positive displacement type used to produce a flow of hydraulic fluid. Flow rate depends on the pump size, the speed at which it is driven and the resistance or pressure it is pumping against.

Pump ratings in GPM at 1200 RPM and at 2000 PSI. For ratings at other speeds refer to the application chart below

Rotation is right hand clockwise facing shaft end.

We stock Pumps, Repair Parts, Seal Kits, Shafts, Bearings & Foot Mounts

FOR ALL UNITS

To determine direction of shaft rotation, view the unit with the shaft pointing toward you, and the idler (driven) gear beneath the shaft. With clockwise rotation, flow will be left to right. The inlet port will be on the left, outlet on the right. The flow is in the opposite direction with counter-clockwise rotation. Inverting the pump will reverse the inlet and outlet ports but not the direction of rotation.

**CUSTOM BUILT PUMPS BUILT FROM PARTS
ARE NON-RETURNABLE**

TO CHANGE ROTATION on P300 series double pumps rotate the gear housing 180° & rotate all of the thrust plates 180° being careful not to lose the channel seals on the backside of them. Also rotate the bearing carrier 180° and rotate the rear cover 180°.

Pump With Splined Shaft and Flange Mount Number	Max. Pres- sure PSI	Gallons Output & Horsepower Required at 1500 PSI											
		Shaft End Pump						Cover End Pump					
		1200 RPM		1800 RPM		2400 RPM		1200 RPM		1800 RPM		2400 RPM	
		GPM OutPut	HP InPut	GPM OutPut	HP InPut	GPM OutPut	HP InPut	GPM OutPut	HP InPut	GPM OutPut	HP InPut	GPM OutPut	HP InPut
P330B497FJAB10-25KMAB07-1	3500	8.5	9.9	14.0	16.3	19.0	22.2	7.0	8.2	10.7	12.5	17.0	19.8
P330B497FJAB12-25KMAB10-1	3500	11.5	13.4	18.0	21.0	24.0	28.0	8.5	9.9	14.0	16.3	19.0	22.2
P330B497FJAB15-25KMAB12-1	3500	14.0	16.3	21.5	25.1	29.0	33.8	11.5	13.4	18.0	21.0	24.0	28.0
P330B497FJAB17-25KMAB15-1	3250	16.0	18.7	25.0	29.2	34.0	39.7	14.0	16.3	21.5	25.1	29.0	33.8
P330B497FJAB20-25KMAB17-1	3000	18.5	21.6	29.0	33.8	39.0	45.5	16.0	18.7	25.0	29.2	34.0	39.7
P350B442FBAB10-7KBAB07-1	3500	11.5	13.4	17.5	20.4	24.5	28.6	9.0	10.5	13.7	16.0	18.5	21.6
P350B442FBAB12-7KBAB10-1	3500	15.0	17.5	23.0	26.8	31.0	36.2	11.5	13.4	17.5	20.4	24.5	28.6
P350B442FBAB15-7KBAB12-1	3500	18.0	21.0	27.5	32.1	37.0	43.2	15.0	17.5	23.0	26.8	31.0	36.2
P350B442FBAB17-7KBAB15-1	3250	21.0	24.5	32.5	37.9	44.0	51.3	18.0	21.0	27.5	32.1	37.0	43.2
P350B442FBAB20-7KBAB17-1	3000	24.0	28.0	37.5	43.8	51.0	59.5	21.0	24.5	32.5	37.9	44.0	51.3
P350B442FBAB22-7KBAB20-1	2750	27.0	31.5	42.0	49.0	57.0	66.5	24.0	28.0	37.5	43.8	51.0	59.5
P350B442FBAB25-7KBAB22-1	2500	30.0	35.0	47.0	54.8	63.5	76.1	27.0	31.5	42.0	49.0	57.0	66.5
P365B478FBAB10-7KBAB07-1	3500	15.5	18.1	24.5	28.6	34.0	39.7	12.2	14.2	19.0	22.2	26.7	31.2
P365B478FBAB12-7KBAB10-1	3500	20.0	23.3	31.5	36.8	43.0	50.2	15.5	18.1	24.5	28.6	34.0	39.7
P365B478FBAB15-7KBAB12-1	3500	24.5	28.6	38.0	44.3	52.5	61.3	20.0	23.3	31.5	36.8	43.0	50.2
P365B478FBAB17-7KBAB15-1	3500	29.0	33.8	45.5	53.1	62.0	72.4	24.5	28.6	38.0	44.3	52.5	61.3
P365B478FBAB20-7KBAB17-1	3500	33.5	39.1	52.0	60.7	71.0	82.9	29.0	33.8	45.5	53.1	62.0	72.4
P365B478FBAB22-7KBAB20-1	2500	38.0	44.3	59.0	68.8	80.5	93.9	33.5	39.1	52.0	60.7	71.0	82.9
P365B478FBAB25-7KBAB22-1	3000	43.0	50.2	66.0	77.0	90.0	100.5	38.0	44.3	59.0	68.8	80.5	93.9

COMMERCIAL HIGH PERFORMANCE SINGLE GEAR MOTORS WITH ROLLER BEARING

WHEN YOU NEED TO REPLACE A MOTOR. WE HAVE IT IN STOCK.

FIRST: Pick the flange type you need looking across drawing below.

SECOND: Pick either splined or round shaft under your drawing.

THIRD: Pick out your High Performance Motor that fits your need under your drawing.
REVERSIBLE SINGLE GEAR MOTORS - HIGH SPEED - HIGH PRESSURE

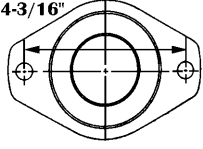
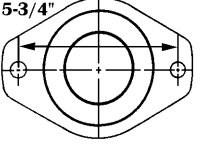
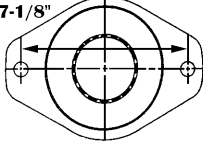
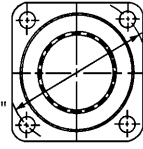
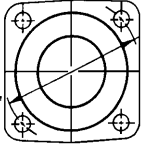
2 BOLT TYPE A 3-1/4" Round Pilot 4-3/16" Bolt Circle	2 BOLT TYPE B 4" Round Pilot 5-3/4" Bolt Circle	2 BOLT TYPE C 5" Round Pilot 7-1/8" Bolt Circle	4 BOLT TYPE B 4" Round Pilot 5" Bolt Circle	4 BOLT TYPE C 5" Round Pilot 6-3/8" Bolt Circle
				
<p>7/8" Rd. Shaft M20X894XXX-30 M30X894XXX-30</p> <p>7/8" 13 Spl. Shaft M20X894XXX-25 M30X894XXX-25</p> <p>1" Rd. Shaft M20X894XXX-43 M30X894XXX-43</p>	<p>7/8" Rd. Shaft M20X897XXX-30 M30X897XXX-30 M50X897XXX-30</p> <p>1" Rd. Shaft M20X897XXX-43 M30X897XXX-43</p> <p>1-1/4" Rd. Shaft M50X897XXX-11</p> <p>7/8" 13 Spl. Shaft M20X897XXX-25 M30X897XXX-25 M50X897XXX-25</p> <p>1-1/4" 14 Spl. Shaft M20X897XXX-7 M30X897XXX-7 M50X897XXX-7</p>	<p>1-1/4" Rd. Shaft M50X898XXX-11 M75X898XXX-11</p> <p>1-1/4" 14 Spl. Shaft M50X898XXX-7 M75X898XXX-7</p>	<p>7/8" Rd. Shaft M20X842XXX-30 M30X842XXX-30 M50X842XXX-30 M75X842XXX-30</p> <p>1" Rd. Shaft M20X842XXX-43 M30X842XXX-43</p> <p>1-1/4" Rd. Shaft M50X842XXX-11 M75X842XXX-11</p> <p>7/8" 13 Spl. Shaft M20X842XXX-25 M30X842XXX-25 M50X842XXX-25</p> <p>1-1/4" 14 Spl. Shaft M20X842XXX-7 M30X842XXX-7 M50X842XXX-7 M75X842XXX-7</p>	<p>1-1/4" Rd. Shaft M30X878XXX-11 M50X878XXX-11 M75X878XXX-11</p> <p>1-1/4" 14 Spl. Shaft M30X878XXX-7 M50X878XXX-7 M75X878XXX-7</p>

Motors in this series are positive displacement to produce a definite speed at a particular rate of flow and give a certain value of torque at a particular pressure.
CUSTOM BUILT MOTORS BUILT DIFFERENT FROM STANDARD MOTORS SHOWN BELOW ARE MORE EXPENSIVE

Motor With ROUND Shaft & Roller Bearing Part Number	Motor With SPLINED Shaft & Roller Bearing Part Number	Max. Speed RPM	Port Size & Type & Location	Max. Pres- sure PSI	Gallons Output & Horsepower Required at 2000 PSI			
					1200 RPM GPM Input	HP Output	1800 RPM GPM Input	HP Output
M20A897MEAB05-30	M20A842MEAB05-25	2400	12P12P-E	3000	7	5	10	8
M20A842MEAB07-30	M20A842MEAB07-25	2400	12P12P-E	3000	9	8	13	12
M20A897BEIF10-30	M20A842BEIF10-25	2400	12P12P-E	3000	13	11	18	16
M20A842BEIF12-30	M20A897BEIF12-25	2400	12P12P-S	3000	16	14	23	21
M20A897BEYF15-30	M20A842BEYF15-25	2400	16P16P-S	3000	18	17	26	25
M20A842BEYF17-30	M20A842BEYF17-25	2400	16P16P-S	2500	21	20	30	29
M20A897BEYL20-30	M20A842BEYL20-25	2400	20P20P-S	2500	23	22	34	33
M30A897MEAB05-30	M30A842MEAB05-25	2400	12P12P-E	2500	7	5	10	8
M30A842MEAB07-30	M30A897MEAB07-25	2400	12P12P-E	2500	9	8	13	12
M30A897BEIF10-30	M30A897BEIF10-25	2400	12P12P-E	2500	13	11	18	16
M30A897BEIF12-30	M30A897BEIF12-25	2400	12P12P-S	2500	16	14	23	21
M30A897BEYF15-30	M30A842BEYF15-25	2400	16P16P-S	2000	18	17	26	25
M30A897BEYF17-30	M30A897BEYF17-25	2400	16P16P-S	2000	21	20	30	29
M30A842BEYL20-30	M30A842BEYL20-25	2400	20P20P-S	2000	23	22	34	33
M50A898BEIJ10-11	M50A897BEIF10-25	2400	12P12P-S	2500	15	13	22	19
M50A878BEIJ12-11	M50A842BEIF12-25	2400	12P12P-S	2500	19	17	27	26
M50A898BEYG15-11	M50A897BEYF15-25	2400	16P16P-S	2500	22	21	33	30
M50A878BEYJ17-11	M50A842BEYF17-25	2400	16P16P-S	2000	25	24	38	35
M50A898BEYL20-11	M50A878BEYL20-7	2400	20P20P-S	2000	30	28	44	41
M50A898BEYL22-11	M50A898BEYL22-7	2400	20P20P-S	2000	33	31	49	46
M50A878BEYL25-11	M50A878BEYL25-7	2400	20P20P-S	2000	37	35	54	49
2 BOLT C WITH SPLINE SHAFT								
4 BOLT C WITH SPLINE SHAFT								
M75A898BEIF10-7	M75A878BEIF10-7	2400	12P12P-S	2500	27	20	38	28
M75A898BEYF12-7	M75A878BEYF12-7	2400	16P16P-S	2500	33	25	46	33
M75A898BEYF15-7	M75A878BEYF15-7	2400	16P16P-S	2500	38	31	54	45
M75A898BEYF17-7	M75A878BEYF17-7	2400	16P16P-S	2500	43	36	63	54
M75A898BEYL20-7	M75A878BEYL20-7	2400	20P20P-S	2000	49	42	71	62
M75A898BEYL22-7	M75A878BEYL22-7	2400	20P20P-S	2000	54	48	80	72
M75A898BEYL25-7	M75A878BEYL25-7	2400	20P20P-S	2000	60	54	87	79
M75A898BEYL27-7	M75A878BEYL27-7	2400	20P20P-S	2000	66	61	97	90
M75A898BEYL30-7	M75A878BEYL30-7	2400	20P20P-S	2000	72	68	103	99

COMMERCIAL HIGH PERFORMANCE SINGLE GEAR MOTORS WITH ROLLER BEARING

WHEN YOU NEED TO REPLACE A MOTOR. WE HAVE IT IN STOCK.

FIRST: Pick the flange type you need looking across drawing below.

SECOND: Pick either splined or round shaft under your drawing.

THIRD: Pick out your High Performance Motor that fits your need under your drawing.

REVERSIBLE SINGLE GEAR MOTORS - HIGH SPEED - HIGH PRESSURE

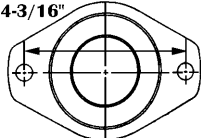
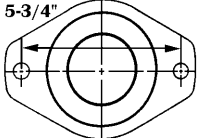
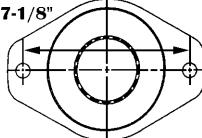
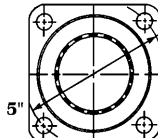
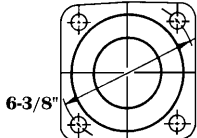
<p>2 BOLT TYPE A 3-1/4" Round Pilot 4-3/16" Bolt Circle</p>  <p>2 BOLT TYPE A 3-1/4" Round Pilot 4-3/16" Bolt Circle</p> <p>7/8" Rd. Shaft M15H901XX-2 M15X994XX-30</p> <p>1" Rd. Shaft M15H901XX-11 M15X994XX-43</p> <p>1-1/4" Rd. Shaft M15H901XX-25</p>	<p>2 BOLT TYPE B 4" Round Pilot 5-3/4" Bolt Circle</p>  <p>2 BOLT TYPE B 4" Round Pilot 5-3/4" Bolt Circle</p> <p>7/8" Rd. Shaft M15H907XX-2 M25X797XX-30</p> <p>1" Rd. Shaft M15H907XX-11 M15X997XX-43 M25X997XX-43</p> <p>1-1/4" Rd. Shaft M15H907XX-25 M25X797XX-11</p>	<p>2 BOLT TYPE C 5" Round Pilot 7-1/8" Bolt Circle</p>  <p>2 BOLT TYPE C 5" Round Pilot 7-1/8" Bolt Circle</p> <p>1-1/4" Rd. Shaft M25X798XX-11 M37X798XX-11</p>	<p>4 BOLT TYPE B 4" Round Pilot 5" Bolt Circle</p>  <p>4 BOLT TYPE B 4" Round Pilot 5" Bolt Circle</p> <p>7/8" Rd. Shaft M15H903XX-25 M25X778XX-11 M37X778XX-11</p> <p>1" Rd. Shaft M15H300XX-11 M15X300XX-43 M25X942XX-43</p> <p>1-1/4" Rd. Shaft M15H300XX-25 M15X300XX-25 M25X942XX-11 M37X942XX-11</p>	<p>4 BOLT TYPE C 5" Round Pilot 6-3/8" Bolt Circle</p>  <p>4 BOLT TYPE C 5" Round Pilot 6-3/8" Bolt Circle</p> <p>1-1/4" Rd. Shaft M15H303XX-25 M15X303XX-25 M25X978XX-11 M37X978XX-11</p>
--------------------------------------------------------------------------------------------------------------------------------------------------------------------------------------------------------------------------------------------------------------------------------------------------------------------------------------------------------------------------------------------------------------------	--------------------------------------------------------------------------------------------------------------------------------------------------------------------------------------------------------------------------------------------------------------------------------------------------------------------------------------------------------------------------------------------------------------------------------------------	------------------------------------------------------------------------------------------------------------------------------------------------------------------------------------------------------------------------------------------------------------------------------------------------	------------------------------------------------------------------------------------------------------------------------------------------------------------------------------------------------------------------------------------------------------------------------------------------------------------------------------------------------------------------------------------------------------------------------------------------------------------------------------------------	------------------------------------------------------------------------------------------------------------------------------------------------------------------------------------------------------------------------------------------------------------------------------------------------------------------------------------

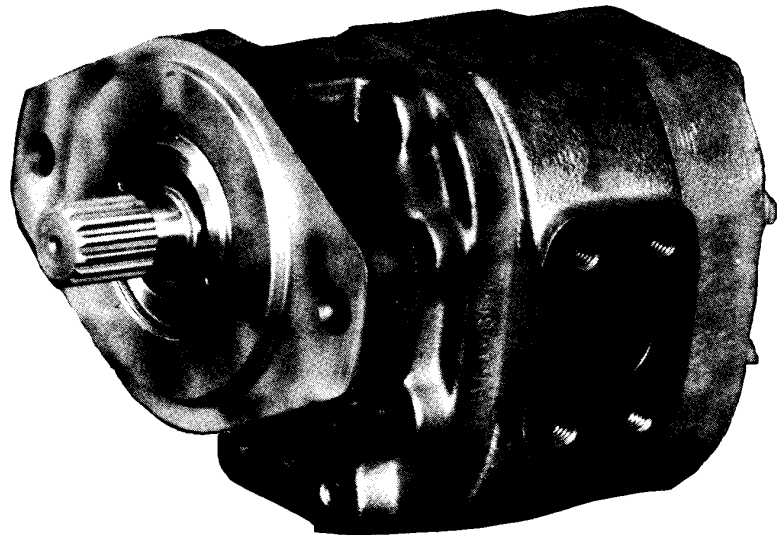

Motors in this series are positive displacement to produce a definite speed at a particular rate of flow and give a certain value of torque at a particular pressure. Refer to the chart below for more information.

Motor With One Piece Shaft & Roller Bearing Part Number	Torque in Lbs.	Max. Speed RPM	Port Size & Type & Location	Max. Pres- sure PSI	Gallons Output & Horsepower Required at 2000 PSI					
					1200 RPM		1800 RPM		2400 RPM	
					GPM Input	HP Output	GPM Input	HP Output	GPM Input	HP Output
M15H901GEAB05-2	184	2000	8P8P-E	2000	4.5	3.6	6.75	5.4	9.0	7.2
M15H901GEAB07-2	276	2000	8P8P-E	2000	6.75	5.4	10.1	8.1	13.5	10.8
M15H901LEAB10-2	368	2000	12P12P-E	2000	9.0	7.2	13.5	10.8	18.0	14.4
M15H901BEIL12-2	460	2000	16P16P-S	2000	11.4	9.6	17.1	14.4	22.8	19.2
M15H901BEIL15-2	551	2000	16P16P-S	2000	13.2	12.0	19.8	18.0	26.4	24.0
M15H907BEIT17-2	643	2000	20P20P-S	2000	15.6	13.8	23.4	20.7	31.2	27.6
M15H907BEIT20-2	735	2000	20P20P-S	2000	18.0	15.6	27.0	23.4	36.0	31.2
M15X994BEIF07-30	468	2500	12P12P-S	2500	6.75	5.4	10.1	8.1	13.5	10.8
M15X994BEYF10-30	613	2500	16P16P-S	2500	9.0	7.2	13.5	10.8	18.0	14.4
M15X994BEYF12-30	765	2500	16P16P-S	2500	11.4	9.6	17.1	14.4	22.8	19.2
M15X994BEYL15-30	799	2250	20P20P-S	2500	13.2	12.0	19.8	18.0	26.4	24.0
M15X994BEYL17-30	812	2000	20P20P-S	2500	15.6	13.8	23.4	20.7	31.2	27.6
M25X797BEER10-30	680	2000	12P12P-S	2000	15.5	13.0	23.0	19.0	31.0	26.0
M25X797BEIL15-30	1075	2000	16P16P-S	2000	22.5	20.0	33.75	30.0	45.0	40.0
M25X797BEIT20-30	1450	2000	20P20P-S	2000	30.5	27.0	45.75	41.0	61.0	55.0
M25X797BEIT25-30	1840	2000	20P20P-S	2000	37.5	35.0	56.25	52.5	75.0	70.0
M37X778BEER10-11	750	2000	12P12P-S	2000	19.2	14.2	26.5	21.3	35.3	28.4
M37X778BEIL15-11	1200	2000	16P16P-S	2000	27.6	22.5	39.0	33.7	52.0	44.9
M37X778BEIT20-11	1650	2000	20P20P-S	2000	37.2	31.0	52.0	46.6	69.3	62.1
M37X778BEIT25-11	2125	2000	20P20P-S	2000	45.6	40.3	64.0	60.4	85.3	80.5
M37X778BEJC30-11	2670	2000	24P24P-S	2000	52.8	50.2	76.0	75.3	101.3	100.3