

**DRIVE RATIOS with PULLEYS & BELTS
SAME SPEED & SAME TORQUE**

A Motor running at 600 RPM Speed and 2,500 pounds pressure requires 16 gallons and develops 1,600 inch-pounds of torque and 15 horsepower. With a 4-inch driving and a 4-inch driven pulley (1 to 1 ratio), this torque and horsepower are transmitted to the driven shaft. The driven shaft has 600 RPM speed and 1,600 inch-pounds of torque and 15 horsepower.

SPEED REDUCTION & TORQUE INCREASE

A Motor running at 600 RPM Speed and 2,500 pounds pressure requires 16 gallons and develops 1,600 inch-pounds of torque. With a 4-inch drive pulley and a 16-inch driven pulley (1 to 4 ratio) it runs the equipment at 150 RPM speed and develops 6,400 inch-pounds of torque and 15 horsepower.

SPEED INCREASE & TORQUE REDUCTION

A Motor running at 600 RPM Speed and 2,500 pounds pressure requires 16 gallons and develops 1,600 inch-pounds of torque. With a 16-inch drive pulley and a 4-inch driven pulley (4 to 1 ratio) it runs the equipment at 2,400 RPM speed and develops 400 inch-pounds of torque and 15 horsepower.

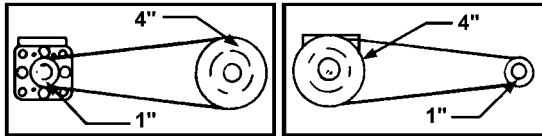

**SPEED REDUCTION
AND TORQUE
INCREASE**

**SPEED INCREASE
AND TORQUE
REDUCTION**

TRW ROSS TORQMOTORS

MPH vs RPM & Flow with Different Rolling Radius Wheels

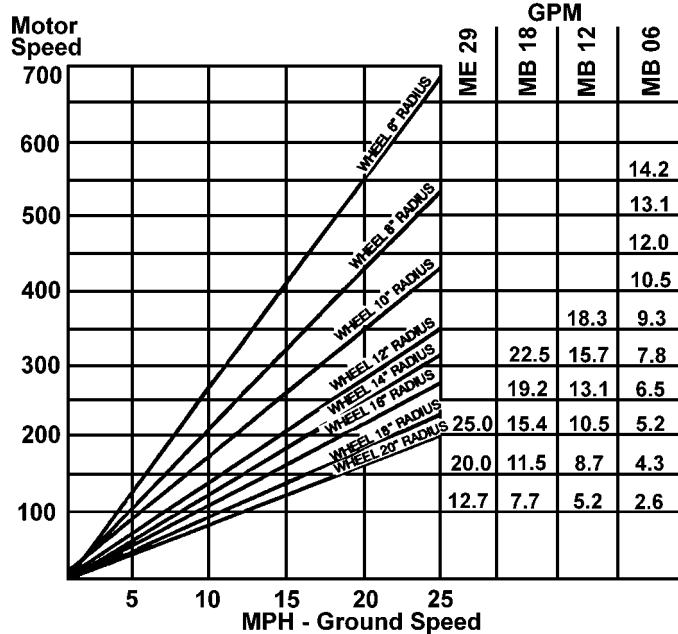

**HOW TO MEASURE TORQUE
REQUIRED FOR A MOTOR**

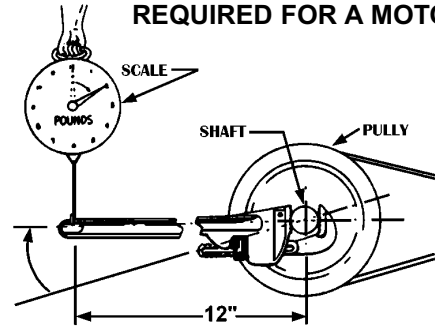

TORQUE is important because it is the measurement of rotary or turning force. Torque is expressed in inch-pounds.

A simple spring scale and a wrench can be used to determine the amount of torque required to turn a shaft. Place a 12 inch pipe wrench on the shaft, attaching the wrench's handle to the spring scale. Pull on the other end of the scale, reading the dial when the shaft moves. This figure (number of pounds) when multiplied by the length of the wrench (in this case 12 inches) will give the torque required to turn the shaft.

EXAMPLE: A 50 pound pull on the end of a 12 inch wrench indicates 600 inch-pounds of torque (50 x 12 = 600).

**TORQUE HORSEPOWER SPEED RELATIONSHIP
FOR HYDRAULIC MOTORS**

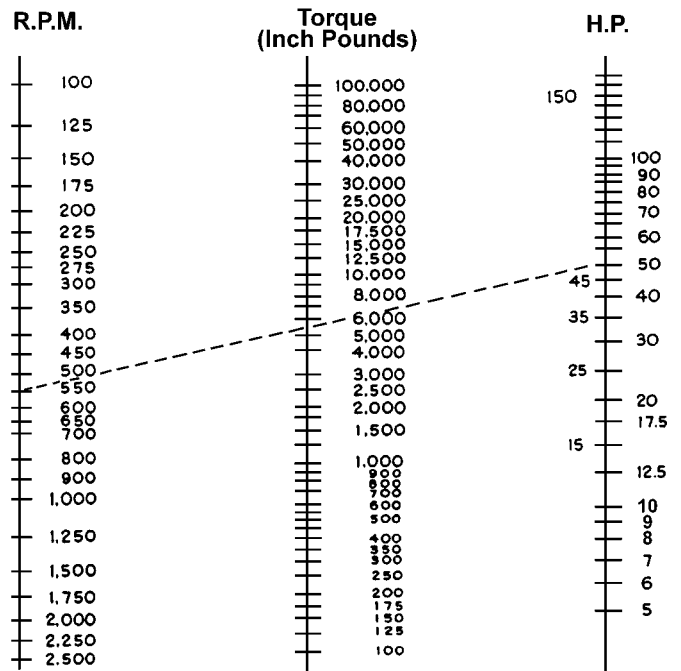

RULE OF THUMB FOR HYDRAULIC MOTOR APPLICATIONS

- Where Gasoline Engines or Electric Motors Are Now Used
- 1 Electric Motor H.P. Equals 1-1/2 Hydraulic Motor H.P.
- 1 Gasoline Engine H.P. Equals 3/4 Hydraulic Motor H.P.
- 1 Hydraulic Motor H.P. Equals 1-2/3 Gasoline Engine H.P.
- 1 Hydraulic Motor H.P. Equals 2/3 Electric Engine H.P.
- 1 Electric Motor H.P. Equals 2-1/2 Gasoline Engine H.P.

TF and TG SERIES MODEL NUMBER EXPLANATION

Example: **TF0080-US-080-AAAA** This model number identifies an MB series motor with a 5 in 3/revolution displacement, a standard mount housing with 7/8 inch O-Ring, a long 6B shaft with snapwire groove and standard black paint.

| TF Series | TG Series | Displacements Cu. Inch/rev | Housing | Shaft | Option |
|-----------|-----------|-------------------------------|---------------------------------|--------------------------------|------------------|
| TF0080 | | 4.9 | -MF Standard mount 7/8 O-Ring | -01 Long 6B snapwire groove | -AAAA "Standard" |
| TF0100 | | 6.1 | -US Long wheel mount 7/8 O-Ring | -02 Long Woodruff, 1/4" tap | |
| TF0130 | | 7.8 | snapwire groove | black paint | |
| TF0140 | | 8.6 | -MB Standard mount rearport | -03 1.25" straight keyed | -AAAB Unpainted |
| TF0170 | | 10.3 | -UB Long wheel mount rearport | -04 10B spline | |
| TF0195 | TG0195 | 12.0 | -AS SAE 2 bolt 7/8 O-Ring | -05 14 tooth spline | |
| TF0240 | TG0240 | 14.5 | -AB SAE 2 bolt rearport | -06 19 tooth spline | |
| TF0280 | TG0280 | 17.1 | | -07 15 tooth spline | |
| | TG0335 | 20.6 | | -08 1.25" tapered shaft | |
| TF0405 | TG0405 | 24.7 | | -19 1.38" tapered shaft | |
| | TG0475 | 29.1 | | -20 1.38" straight keyed shaft | |
| | TG0530 | 32.3 | | | |
| | TG0625 | 38.0 | | | |
| | TG0785 | 48.0 | | | |
| | TG0960 | 58.5 | | | |